

Lecture 2: Finite Elements

In finite element analysis, functions of continuous quantities such as temperature or displacements, can be represented by piecewise approximations. Thus, a finite element representation of a circle would be a circumscribed polygon, with each edge being a finite element. The deflection of a mechanically heterogeneous structure as a function of force may be described by dividing it into small elements, each of which can be approximated to be homogeneous.

In finite element stress analysis, the elastic body is first divided into discrete connected parts, which are the *finite elements*. The points at which the elements are connected are the *nodes*. The process of dividing the domain into elements is called *discretisation* and the pattern of elements is the *mesh*. We then relate, using a *stiffness matrix*, the forces applied to the nodes of a single element and the resultant nodal displacements. The final step is to combine together all the stiffness matrices of the individual elements into a single large matrix which is the *global stiffness matrix*. We shall now illustrate this process using linear elastic springs.

Single Spring

Assume that the force versus displacement relation is linear,

$$F = k\delta$$

where k is the stiffness of the spring. The spring shown in Fig. 1a is fixed at one end and hence at equilibrium can only have a displacement δ at the other node.

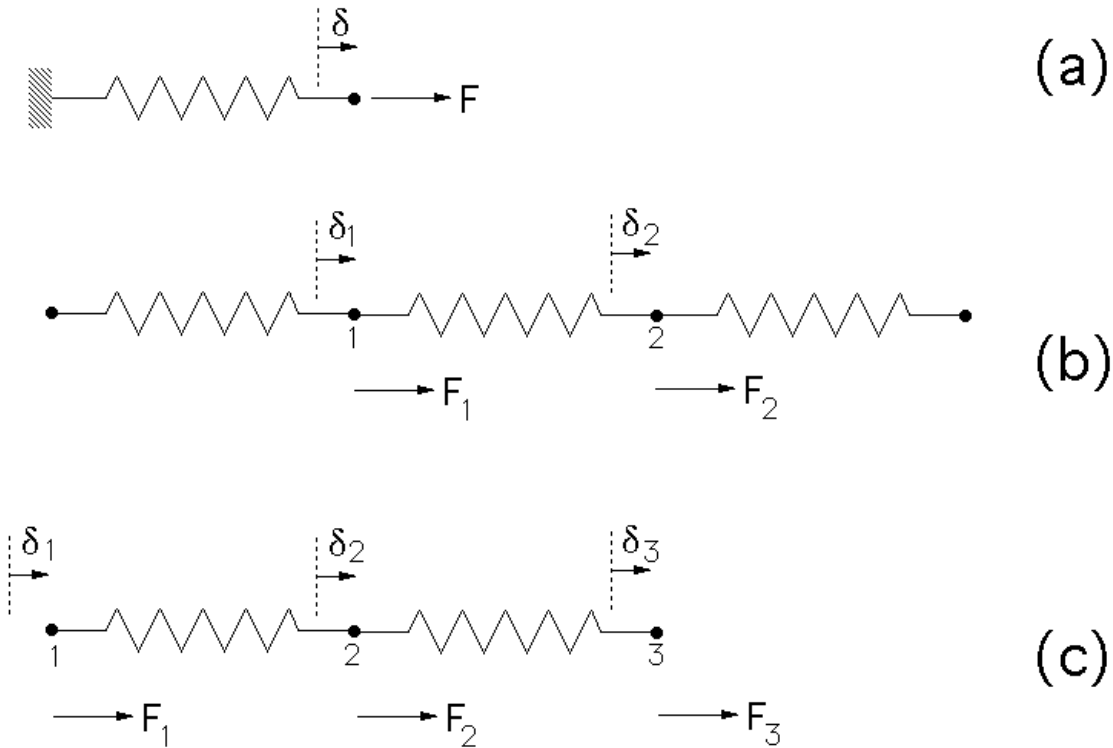

Fig. 1: (a) Single spring, fixed at one end. (b) Spring in a system of springs. (c) System of two springs.

Spring in a System of Springs

Fig. 1b shows a system of springs, each of stiffness k but with a distribution of forces. For the particular spring identified by the nodes 1 and 2 in that system of springs, there are the forces F_1 and F_2 respectively. At equilibrium $F_1 + F_2 = 0$ or $F_2 = -F_1$. Since node 1 is displaced δ_1 and node 2 a distance δ_2 , the net displacement is $(\delta_2 - \delta_1)$

with

$$F_2 = k(\delta_2 - \delta_1)$$

$$F_1 = k(\delta_1 - \delta_2)$$

These equations can be written in matrix form as

$$\mathbf{f} = \mathbf{k}\mathbf{d}$$
$$\begin{bmatrix} F_1 \\ F_2 \end{bmatrix} = \begin{pmatrix} k & -k \\ -k & k \end{pmatrix} \begin{bmatrix} \delta_1 \\ \delta_2 \end{bmatrix}$$

System of Two Springs

Fig. 1c shows a system at equilibrium, consisting of a pair of springs, with different stiffnesses k_1 and k_2 . It follows that

$$F_1 + F_2 + F_3 = 0$$

and that

$$F_1 = k_1(\delta_1 - \delta_2)$$

$$F_3 = k_2(\delta_3 - \delta_2)$$

so that

$$F_2 = -k_1\delta_1 + (k_1 + k_2)\delta_2 - k_2\delta_3$$

which may be written as

$$\mathbf{F} = \mathbf{K}\mathbf{D}$$
$$\begin{bmatrix} F_1 \\ F_2 \\ F_3 \end{bmatrix} = \begin{pmatrix} k_1 & -k_1 & 0 \\ -k_1 & k_1 + k_2 & -k_2 \\ 0 & -k_2 & k_2 \end{pmatrix} \begin{bmatrix} \delta_1 \\ \delta_2 \\ \delta_3 \end{bmatrix}$$

The overall stiffness matrix \mathbf{K} can be derived from the individual stiffness matrices \mathbf{k}_1 and \mathbf{k}_2 but their orders are different so the latter two have to be expanded as follows:

$$\begin{bmatrix} F_1 \\ F_2 \\ 0 \end{bmatrix} = \begin{pmatrix} k_1 & -k_1 & 0 \\ -k_1 & k_1 & 0 \\ 0 & 0 & 0 \end{pmatrix} \begin{bmatrix} \delta_1 \\ \delta_2 \\ \delta_3 \end{bmatrix}$$

$$\begin{bmatrix} 0 \\ F_2 \\ F_3 \end{bmatrix} = \begin{pmatrix} 0 & 0 & 0 \\ 0 & k_2 & -k_2 \\ 0 & -k_2 & k_2 \end{pmatrix} \begin{bmatrix} \delta_1 \\ \delta_2 \\ \delta_3 \end{bmatrix}$$

$$\text{with } \mathbf{K} = \begin{pmatrix} k_1 & -k_1 & 0 \\ -k_1 & k_1 & 0 \\ 0 & 0 & 0 \end{pmatrix} + \begin{pmatrix} 0 & 0 & 0 \\ 0 & k_2 & -k_2 \\ 0 & -k_2 & k_2 \end{pmatrix}$$

This simple case illustrates how the properties of the elements can be combined to yield an overall response function.

Minimising the Potential Energy

For the set of springs illustrated in Fig. 2, we write

$$F_1 = k_1(\delta_1 - \delta_2)$$

$$0 = -k_1(\delta_1 - \delta_2) + k_2\delta_2 - k_3(\delta_3 - \delta_2)$$

$$F_3 = k_3(\delta_3 - \delta_2)$$

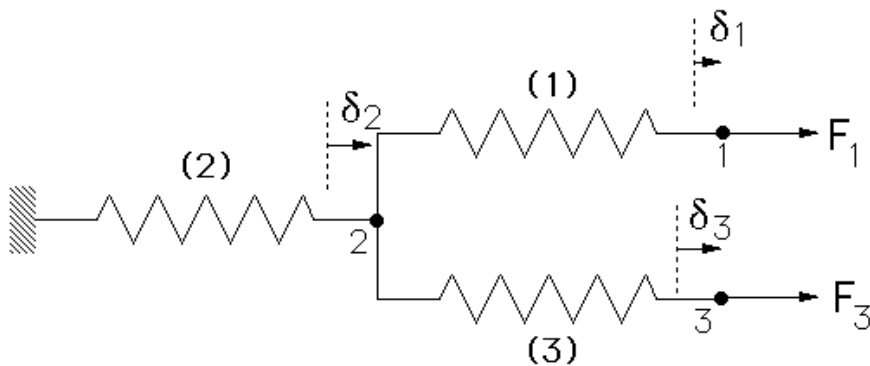

Fig. 2: Another set of springs.

Expressed in matrix form, these equations become

$$\begin{bmatrix} F_1 \\ 0 \\ F_3 \end{bmatrix} = \begin{pmatrix} k_1 & -k_1 & 0 \\ -k_1 & k_1 + k_2 + k_3 & -k_3 \\ 0 & -k_3 & k_3 \end{pmatrix} \begin{bmatrix} \delta_1 \\ \delta_2 \\ \delta_3 \end{bmatrix} \quad (1)$$

The same set of equations could have been derived by considering a minimisation of potential energy Π . The total potential energy after loading is the sum of the strain energy and the reduction of the potential energy of the applied forces during the nodal displacements:

$$\begin{aligned} \Pi &= \text{strain energy} + \text{work potential} \\ &= \frac{1}{2}k_1(\delta_1 - \delta_2)^2 + \frac{1}{2}k_2(\delta_2)^2 + \frac{1}{2}k_3(\delta_3 - \delta_2)^2 + \\ &\quad - F_1\delta_1 - F_3\delta_3 \end{aligned}$$

For equilibrium in a system with three degrees of freedom we need to minimise Π with respect to δ_1 , δ_2 and δ_3 :

$$\begin{aligned} \frac{\partial \Pi}{\partial \delta_1} &= k_1(\delta_1 - \delta_2) - F_1 = 0 \\ \frac{\partial \Pi}{\partial \delta_2} &= -k_1(\delta_1 - \delta_2) + k_2\delta_2 - k_3(\delta_3 - \delta_2) = 0 \\ \frac{\partial \Pi}{\partial \delta_3} &= k_3(\delta_3 - \delta_2) - F_3 = 0 \end{aligned}$$

This result is identical to the one obtained before (equation 1); the potential energy minimisation approach is simpler for large and complex problems.

For the set of springs illustrated in Fig. 3, we write

$$F_1 = k_1(\delta_1 - \delta_2)$$

$$0 = -k_1(\delta_1 - \delta_2) + k_2\delta_2 - k_3(\delta_3 - \delta_2)$$

$$F_3 = k_3(\delta_3 - \delta_2) + k_4\delta_3$$

$$\begin{bmatrix} F_1 \\ 0 \\ F_3 \end{bmatrix} = \begin{pmatrix} k_1 & -k_1 & 0 \\ -k_1 & k_1 + k_2 + k_3 & -k_3 \\ 0 & -k_3 & k_4 \end{pmatrix} \begin{bmatrix} \delta_1 \\ \delta_2 \\ \delta_3 \end{bmatrix}$$

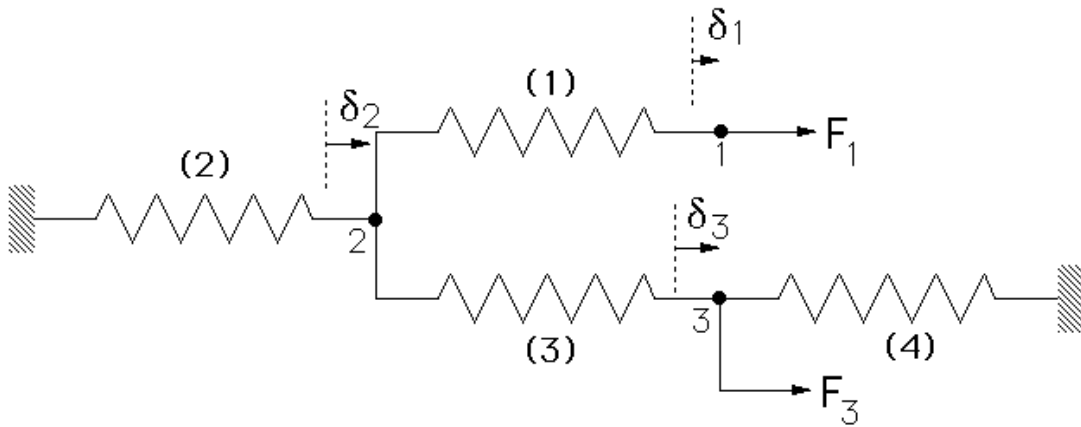

Fig. 3: Another set of springs.

The same set of equations could have been derived by considering a minimisation of potential energy Π :

$$\begin{aligned} \Pi &= \text{strain energy} + \text{work potential} \\ &= \frac{1}{2}k_1(\delta_1 - \delta_2)^2 + \frac{1}{2}k_2(\delta_2)^2 + \frac{1}{2}k_3(\delta_3 - \delta_2)^2 + \frac{1}{2}k_4(-\delta_3)^2 \\ &\quad - F_1\delta_1 - F_3\delta_3 \end{aligned}$$

For equilibrium in a system with three degrees of freedom we need to minimise Π with respect to δ_1 , δ_2 and δ_3 :

$$\frac{\partial \Pi}{\partial \delta_1} = k_1(\delta_1 - \delta_2) - F_1 = 0$$

$$\frac{\partial \Pi}{\partial \delta_2} = -k_1(\delta_1 - \delta_2) + k_2\delta_2 - k_3(\delta_3 - \delta_2) = 0$$

$$\frac{\partial \Pi}{\partial \delta_3} = k_3(\delta_3 - \delta_2) + k_4\delta_3 - F_3 = 0$$

This result is identical to the one obtained before; the potential energy minimisation approach is simpler for large and complex problems.

References

- Crank, J., (1975) *The Mathematics of Diffusion*, Oxford University Press Chapter 8
- Davies, A. J., (1980) *The Finite Element Method*, Clarendon Press, Oxford
- Entwistle, K. M., (1999) *Basic Principles of the Finite Element Method*, The Institute of Materials, London
- Huebner, K. H., (1975) *The Finite Element Method for Engineers*, John Wiley and Sons, London
- Seegerlind, L. J., (1976) *Applied Finite Element Analysis*, John Wiley and Sons, London
- Chandrupatla, T. R. and Belegundu, A. D., (2000) *Finite Elements in Engineering*, 2nd edition, Prentice Hall of India, New Delhi